

Straight Descents and Descending Turns

Objective	
<p>To ensure the applicant learns the proper methods for performing descents and descending turns, as well as has an understanding of the purpose of the flight controls and how airplanes descend.</p>	
Purpose	
<p>Eventually, every flight ends with a landing. To get down to the ground, the airplane must descend. Descents introduce pilots to the concept that allowing gravity to keep the forward speed up can allow airplanes to glide down without engine power, or with reduced engine power. Descents also introduce pilots to basic engine management concepts.</p>	
Schedule	Equipment
<ul style="list-style-type: none"> ● Ground Lesson: 10 minutes ● Flight Lessons <ul style="list-style-type: none"> ■ Flight: 20 minutes - <i>Introduction to Maneuver</i> ■ Flight: 10 minutes (per lesson) - <i>Improve Proficiency (Dual)</i> ● Debrief: 10 minutes (<i>per flight</i>) 	<ul style="list-style-type: none"> ● Airplane Checklist ● Whiteboard / Markers (optional) ● Model Airplane (optional)
Student Actions	Instructor Actions
<ul style="list-style-type: none"> ● Ask any questions, receive study material for the next lesson. ● Watch linked video. ● Review listed references. 	<ul style="list-style-type: none"> ● Deliver the ground lesson (below). ● Demonstrate the maneuver in flight. ● Debrief after each flight.
Completion Standards	
<ul style="list-style-type: none"> ● Ground: Student can explain how airplanes descend and the procedure for initiating a descent. ● Flight: Student can perform the maneuver to the following standards: <ul style="list-style-type: none"> ● Maintains visual scan outside the cockpit while occasionally referencing the flight instruments. ● Trims the airplane appropriately, maintains coordinated flight. ● Initiates a descent and establishes a normal descent pitch attitude and trims for an appropriate descent airspeed. ● As directed by the instructor, turns to a specified heading during the descent. ● Holds heading +/- 10 degrees, maintains airspeed +/- 10 knots, levels off at target altitude +/- 100 feet. 	

References

- Aviation Training Network - "ATPL Training / Principles of Flight #54 Flight Mechanics - Descent"
 - YouTube - <https://www.youtube.com/watch?v=YE8jPbkFktQ> (First 2:00 only)
- FAA-H-8083-3C (Airplane Flying Handbook) - Chapter 3, Page 1-3 [The Four Fundamentals/Effect and Use of Flight Controls], Chapter 3, Page 5-6 [Integrated Flight Instruction], Chapter 3, Page 10 [Trim Control], Chapter 3, Page 20-21 [Descents and Descending Turns]
- FAA-H-8083-25C (Pilot's Handbook of Aeronautical Knowledge) - Chapter 5, Page 1-8 [Forces Acting on an Aircraft/Thrust/Lift/Drag/Weight], Chapter 5, Page 12-13 [Axes of an Aircraft], Chapter 5, Page 22-23 [Forces in Turns], Chapter 5, Page 24-25 [Forces in Descents], Chapter 6, Page 2-8 [Flight Controls/Ailerons/Elevator/Rudder], Chapter 6, Page 10-12 [Trim Systems], Chapter 8, Page 3-4 [Altimeter], Chapter 8, Page 8-9 [Airspeed Indicator], Chapter 8, Page 17-18 [Turn Coordinator], Chapter 8, Page 18-19 [Attitude Indicator]
- FAA-S-ACS-25 (CFI ACS) - Area VIII Task D

Ground Lesson Outline

- Introduction to the Four Fundamentals
 - Straight-and-level, Turns, Climbs, and Descents
 - Most airplanes are inherently stable
 - Yaw/Pitch/Roll
 - Airplanes turn by banking
- The Primary Flight Controls
 - Ailerons, Elevator, Rudder
- The Elevator Trim
 - Relieving elevator pressure, Trim wheel, trim tabs
- Proper Yoke Grip and Overcontrolling
 - One-handed grip, Control movements vs control pressures
- Outside and Inside References - Integrated flight instruction
 - Sight picture, Attitude Indicator, Heading Indicator/Compass/Altimeter/VSI
 - Coordinated flight/turn coordinator
- The Four Forces
 - Weight, Lift, Thrust, Drag
- Relationship of Thrust to Maintaining Altitude
 - Airplanes don't climb or descend with elevator alone
 - Tachometer, listening to the engine
- How Airplanes Descend
 - Power required greater than power setting
 - Forces in descents
 - Descents and Airspeed
 - Effects of Downwash
- Performing Descents and Descending Turns
- Engine Considerations
 - Carb Heat, Clearing the Engine

Common Errors

- **Failure to cross-check and correctly interpret outside and instrument references.**
- **Application of control movements rather than pressures.**
- Uncoordinated use of flight controls.
- **Faulty trim procedure.**
- **Failure to clear engine and to use carburetor heat, as appropriate.**

Ground Lesson Content

- **Introduction to the Four Fundamentals** - The *four fundamentals* of flight are **straight-and-level flight, turns, climbs, and descents**. Every flight training curriculum begins with mastering the fundamentals.
 - Most airplanes are inherently stable. The good news for aspiring pilots is that, for the most part, an airplane can be ‘flown’ without touching the controls at all. Of course, if the airplane is to go where *the pilot* wants it to go, the pilot will need to continuously monitor the airplane and make corrections using the *flight controls*.
 - Unlike cars, which turn only left or right in two dimensions, airplanes can move in three dimensions, and rotate around 3 separate axes. The orientation of the airplane is called the *attitude*. The 3 axes of flight are:
 - **Yaw** - Yaw is the familiar ‘turning’ left and right. Rotating around the *vertical axis*.
 - **Pitch** - Pitch is the up and down axis. The airplane is rotating around the *lateral axis*, and the nose will be pointing ‘uphill’ or ‘downhill’.
 - **Roll** - Roll is somewhat unique to airplanes. **Roll is also often called bank**. The airplane is rotating around the *longitudinal axis*. There is no real similarity to cars in this dimension, but it can be thought of as the airplane *leaning* left or right.

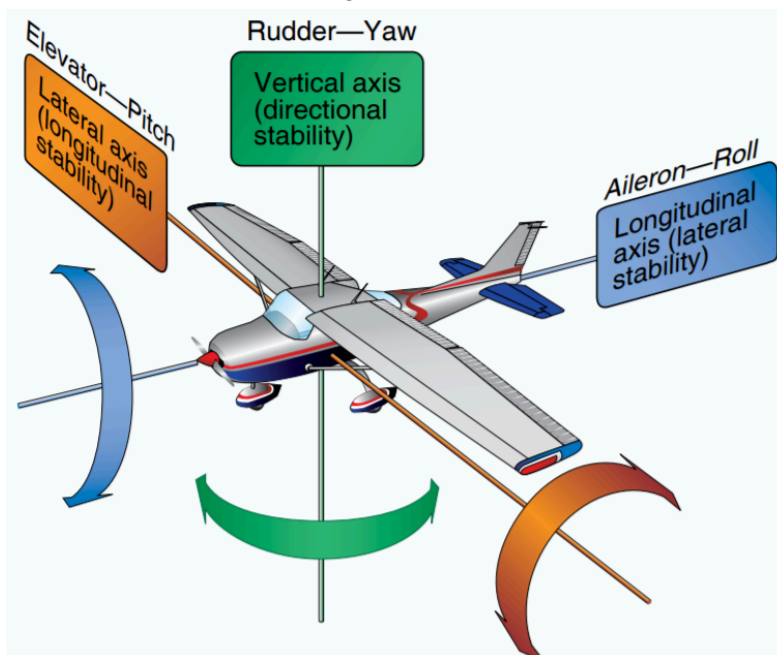

- Airplanes climb and descend in part by increasing or decreasing pitch, however, somewhat unexpectedly, **airplanes do not turn by simply changing yaw. Airplanes turn by banking towards the direction of the turn**, which directs the wings lift force to the side. The vertical tail surface keeps the airplane aligned with the direction of travel, causing the airplane to yaw. This is similar to how the fins or feathers on a dart or arrow keep it flying in the direction it is thrown.

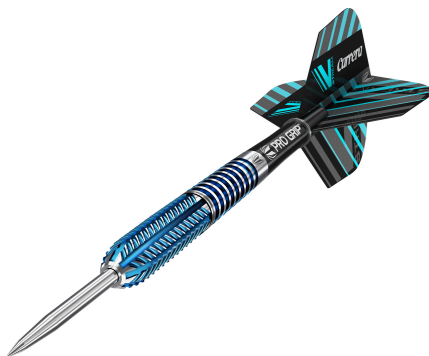

• The Primary Flight Controls

- Airplanes are commonly designed with 3 *primary* flight controls:
 - **Ailerons** - Ailerons move the airplane around its *Roll* axis. **The angle of roll is called the *bank angle* and pilots use the airplane to *bank* in the direction they wish to turn.** Most airplanes control the ailerons with a yoke, which is similar to a steering wheel. Turning the wheel left or right causes the airplane to bank left or right.

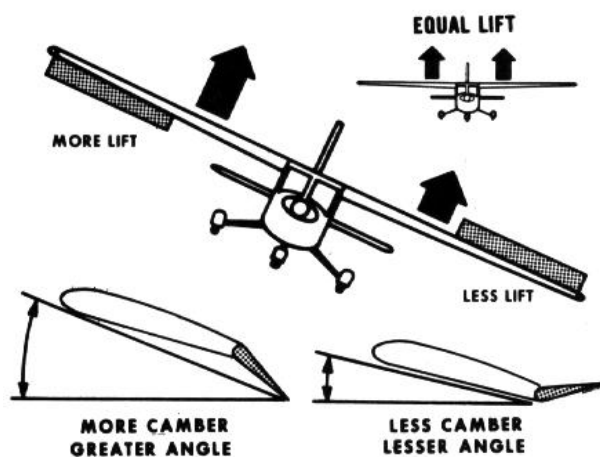
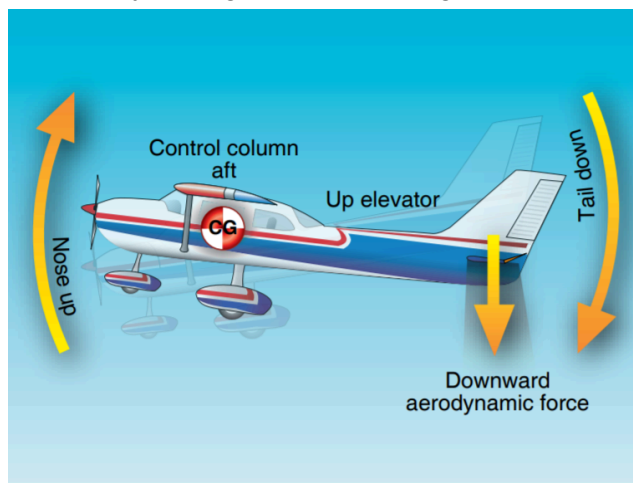
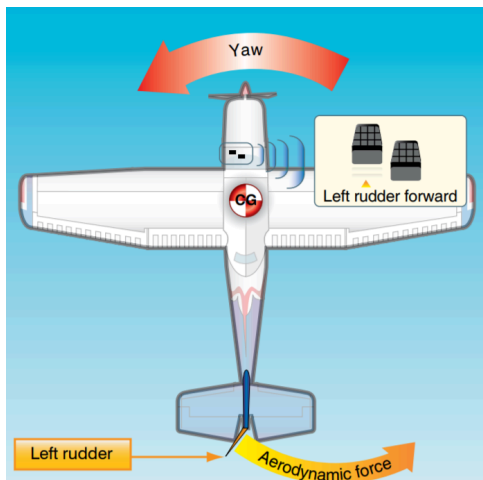

Figure 4-3 Forces Exerted by Ailerons

- **Elevator** - The Elevator moves the airplane around its *Pitch* axis. Pilots can initiate a climb or descent by pulling back or pushing forward on the yoke, respectively.



- Rudder** - The Rudder moves the airplane around its Yaw axis. The rudder is a very mysterious control for most new pilots, because **it is not used to turn the airplane**, as one might expect. The sole purpose of the rudder is to aid the airplane in maintaining a proper (called *coordinated*) flight path during turns made with the ailerons (bank).



- The Elevator Trim** - In order to hold the nose the proper distance from the horizon and maintain altitude, **new pilots often discover that it may require continuous forwards or backwards elevator pressure on the control yoke**. This is not only uncomfortable, it also requires pilots to devote more attention to maintaining straight and level flight and prevents them from multitasking effectively. There is another, *secondary* flight control, called *pitch trim* or *elevator trim*. These terms are interchangeable, and refer to a control wheel (**the trim wheel**) which can be used to relieve these control pressures.
 - The trim mechanism is different on different airplanes, but it usually consists of a small tab, called the *trim tab* on the elevator control surface itself. The trim tab services to 'rebalance' the neutral position of the elevator control and help maintain low control pressures.
 - The trim tab is moved with the *trim wheel*, which when rolled forward moves the trim *nose down*, and when rolled rearwards, moves the trim *nose up*.

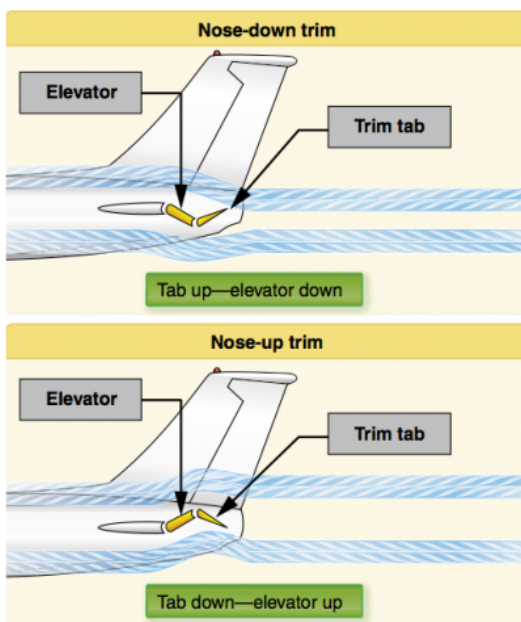

- **Proper Yoke Grip and Overcontrolling** - Proper control of the airplane requires that pilots avoid *overcontrolling*. Unlike driving a car, which requires large movements of the wheel, flying an airplane rarely requires large movements, or a lot of force on the controls.
 - Pilots who grip the yoke tightly with both hands often struggle with maintaining straight and level flight or making smooth turns or other maneuvers. Pilots coping with turbulent or bumpy conditions often make the bumpiness *worse* by holding the yoke too firmly.
 - In most situations, pilots should attempt to relax, as **the airplane can be flown mostly with control pressures, rather than control movements**. A one-handed, light grip on the yoke also frees the pilots other hand for manipulating the throttle, or adjusting the radios, etc.



- **Outside and Inside References** - Pilots use both *outside* (looking out the window) and *inside* (looking at the *flight instruments*) to maintain aircraft attitude. **It is important for pilots to use both of these references when flying an airplane**, to prevent optical illusions or poor outside visibility from disorienting the pilot. Comparing multiple independent sources of information about aircraft attitude is called *cross-checking*. The *integrated flight instruction* method recommended by the FAA emphasizes pilots utilizing both outside and inside references from the very beginning of their flying career to develop proper habits of cross-checking these references.
 - **Descending Sight Picture** - Pilots can visually judge their pitch and bank by using something called a *sight picture*. A sight picture is just a familiar appearance of the horizon relative to the airplane's *instrument panel* (dashboard), and is used to judge the *attitude*.
 - **When descending straight ahead, the sight picture remains similar to straight and level flight, except that the nose will be further below the natural horizon.**
 - When making a descending turn at a given speed, the bank angle should be judged based on the angle the instrument panel makes with the horizon.



- **Judging pitch during turns can be more difficult, as the nose appears to rise or descend when rolling due to the fact that pilots don't sit in the center of the airplane.** Pitch attitude can be more accurately judged by the place on the instrument panel that intersects the horizon.
- Notice that during turns, **the point on the horizon that intersects the instrument panel changes depending on whether the airplane is climbing, flying level, or descending.**



- The *inside* reference for pitch and bank is an instrument called the *attitude indicator*, which is also sometimes called an *artificial horizon*.



- The attitude indicator is used to back up the out-the-window sight picture for all phases of flight: straight-and-level, climbs, turns, and descents.

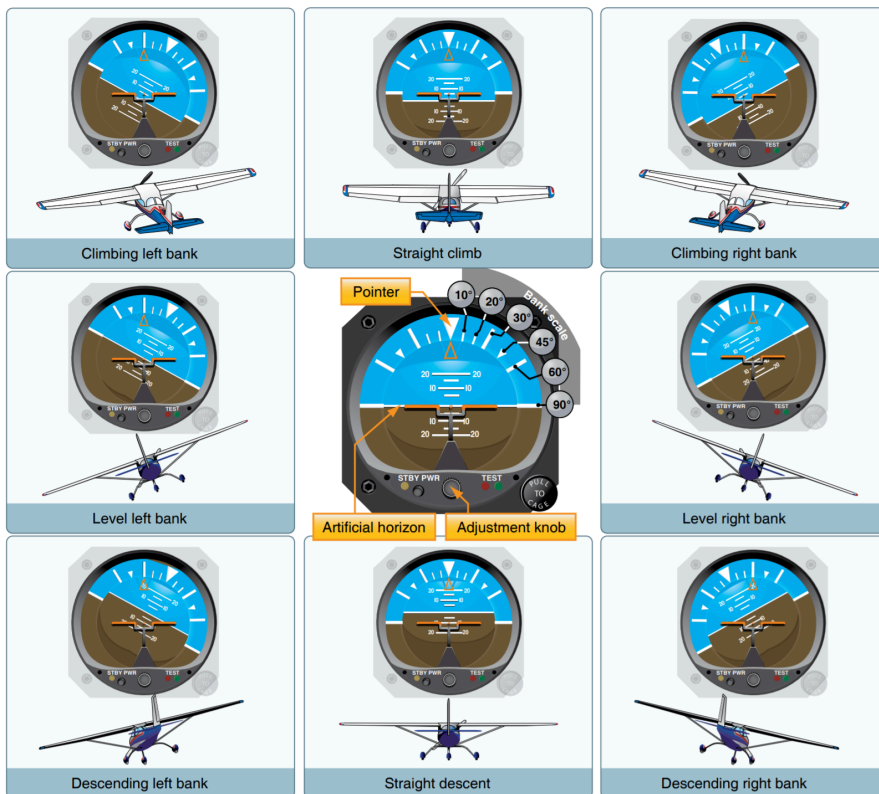

- Pilots also judge their heading by using an instrument called a *directional gyro*, which indicates the compass direction (North, South, East, West, etc) the nose of the airplane is pointing.



- During climbs and descents, the pilot is attempting to gain or lose altitude. Therefore, the performance of the climb or descent must also be monitored by glancing at the *altimeter*, and the *vertical speed indicator*, which shows the *rate* of climb.



- **Coordinated Flight** - Recall from the lesson on turns that when performing climbing or descending turns, the pilot will need to correct for the tendency of the airplane to enter a sideslip or skidding condition by using the rudder pedals to manage the amount of sideslip or skidding as the pilot rolls the airplane or maintains a turn. Flying with no skid or sideslip is called *coordinated flight*. The instrument which gives the pilot direct information about this is called the *turn coordinator*, however **pilots can also learn to sense when they are being pushed away from the turn or towards the turn.**

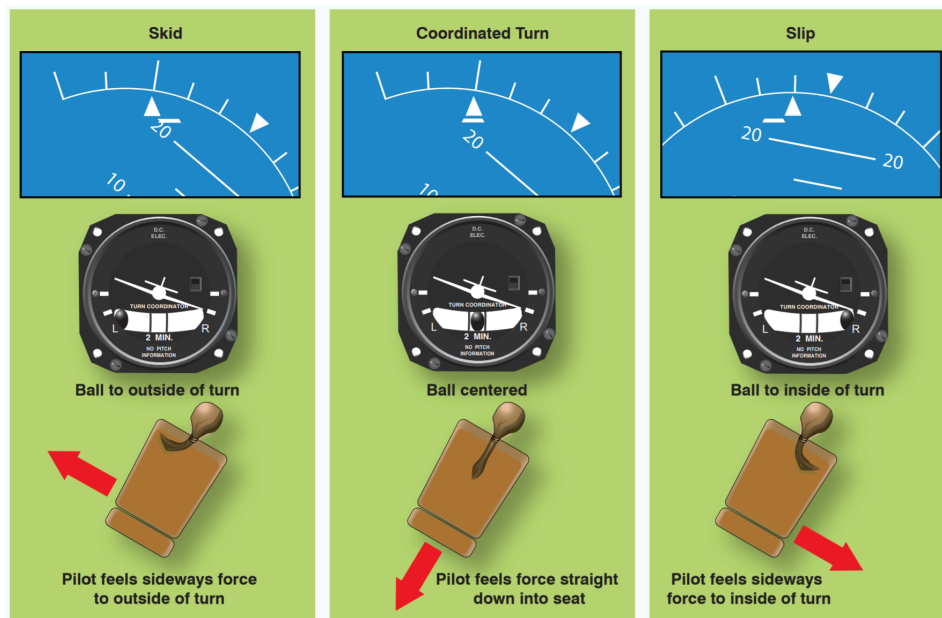

- **The Four Forces** - Airplanes in straight and level flight are subject to 4 basic forces:
 - **Weight** - *Weight* is the downward force provided by gravity. As an airplane sits stationary on the ground, the only force acting on it is gravity.
 - **Lift** - *Lift* is the upward force provided by the wing. As air flows over and around the wing, it is redirected downward, providing an upward force which during flight balances the downward force of gravity.
 - **Thrust** - *Thrust* is the forward force provided by the engine. Airplanes must move forward to generate lift, and this movement is provided by engine thrust.
 - **Drag** - *Drag* is the rearward force of air resistance, which opposes thrust. Most pilots are already familiar with air resistance... holding a hand out of the window of a moving car is a simple demonstration of drag.
- **Relationship of Thrust to Maintaining Altitude** - Most non-pilots generally understand that “the engine makes the airplane go”. Although pilots can use the elevator control to climb, descend, or fly level, without adjusting the *engine thrust*, the airplane may have insufficient power to climb or descend in response to pilot inputs.
 - When an airplane is flying at given speed (called *airspeed*), all of the four forces are in equilibrium, which means that **the thrust precisely equals the drag**. Therefore, a basic task that pilots must accomplish to maintain a constant altitude is managing the engine thrust.

- Somewhat like a car coasting uphill or downhill, **if the airplane is being held at a given altitude with the control yoke, insufficient power will cause the airplane to slow down, and excess power will cause the airplane to speed up.**
- Pilots can manage an airplane's thrust by using another instrument, called the *tachometer*. Similar to a car, it indicates how many revolutions per minute (RPM) the propeller is spinning. Higher values equal more power. It is also useful for pilots to use their ears to judge the power setting. **With experience, pilots can develop the ability to judge whether the power setting is too high or low from the engine noise alone.**



- **How Airplanes Descend** - Aircraft do not necessarily need to have an engine. Gliders are quite popular and work perfectly well without an engine, demonstrating that airplanes can fly for extended periods of time without any engine power at all. However, without an engine, it is very difficult or impossible to *climb*. While gliders can manage this by using the energy of rising air, **conventional powered airplanes are considerably less efficient and can only sustain level flight or climb by using engine power.** When operating without thrust, or with less thrust, a conventional powered airplane behaves somewhat like a glider.
 - Recall from the lesson on climbs that airplanes can only sustain a climb when the power available is greater than the power required to maintain level flight. If there is more power available (if the throttle can be increased), the airplane can climb. Likewise, **if the power required is greater than the current power setting, the airplane will descend.**
 - **Forces in Descents** - During *unaccelerated flight*, such as during straight and level flight, the four forces acting on an airplane are in equilibrium. (If the forces were not equal, the airplane would experience an acceleration in some direction-- up, down, forward, back)
 - **When an airplane initiates a descent, it pitches down, and directs its lift in a slightly forward direction, providing less vertical lift.** Because gravity always acts directly downward, this initially causes an acceleration (downwards), and the airplane begins to descend. Once the airplane stabilizes in the descent, it is now *moving* downwards (descending), but it is no longer *accelerating* downwards (it has a stable vertical rate of descent). It has again returned to the forces being in equilibrium, with **the weight of the airplane acting slightly forward along its flight path, replacing the lowered engine thrust.**

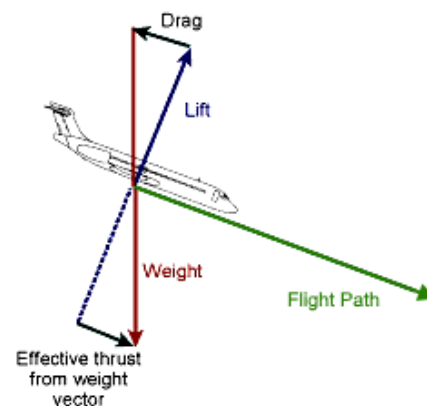

- **Descents and Airspeed** - Because airplanes climb or descend due to excess or insufficient power, it is important to realize that the amount of excess power an airplane has is also dependent on the airspeed. A power setting which produces level flight at a lower speed may create a descent at a higher speed, due to the higher power required. **However, when descending, it is also important to keep the airspeed from rising too much. Like a car coasting downhill, the speed will tend to increase in steep descents.** In an airplane, it is best to descend in the *green arc* on the airspeed indicator, which corresponds to the airspeeds which are safe to fly in turbulent air.



- **Effects of Downwash** - One thing new pilots will notice quite quickly is that **when large reductions in power are made, the nose of the airplane will tend to lower itself automatically.** Although this is partly because the power reduction will cause a descent, it is also partly because the engine's thrust contributes to the downwash over the rear horizontal stabilizer. When the thrust is reduced, there is less downward force on the stabilizer, which allows the nose to fall. Pilots should anticipate this and compensate with elevator trim.

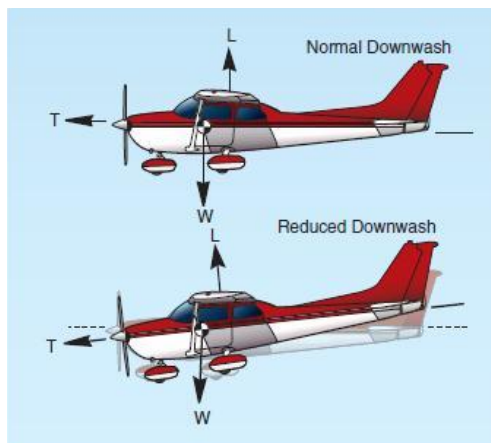

- **Performing Descents and Descending Turns** - Descending turns are quite simply a combination of the basics of descents, and level turns. Although descents require less power than level flight, recall that turns require slightly more power. To begin:
 - **Step 1** - Pilot reduces the engine power and allows the nose to fall into a proper nose-low descent attitude.
 - **Step 2** - Pilot trims nose-up to account for the tendency of the nose to fall and to maintain the desired airspeed.
 - **Step 3 (For a Descending Turn)** - Pilot rolls the airplane to the desired bank angle and begins turning, while adding slightly more backpressure to account for the loss of the vertical component of lift.

- **Engine Considerations** - When descending, the engine is producing less power. Airplane engines are generally designed to run continuously at high power settings. When running at lower power settings, pilots must follow precautions established by the airplane manufacturers:
 - Many airplanes specify that carburetor heat should be applied when run at low power settings to prevent the formation of ice in the carburetor.
 - For prolonged descents, it is a good idea to 'clear' the engine, by momentarily increasing power and then reducing it, to ensure that the engine is still operating normally.